

BLA 200 Ring Chamber Orifice Plate

Application

For differential-pressure flow-rate measurement in aggressive and non-aggressive gaseous and liquid media and steam.

Construction

Two-part carrier-ring with pressure-taps according to DIN 19205 and exchangeable orifice plates. It can be delivered as an orifice according to ISO 5167-2, as quarter circle nozzle or as a double coned orifice according to appropriate conditions of use.

Carrier-ring and orifice plate are supplied with a flat seal. The seal is chosen to suit accurately the medium and the working conditions and the ring chamber orifice plate is secured against damage during transport and installation.

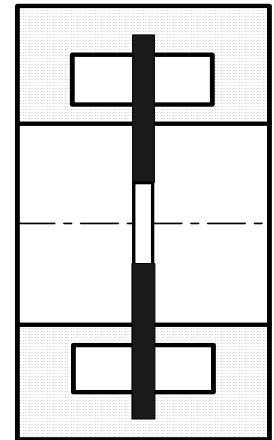

Advantages

As the orifice plate is easily exchangeable alterations in the criteria of measurement are greatly simplified. The ring chamber tapping reduces faults caused by installation; it provides a good average value between the plus and minus pressure-values.

Technical Details

Nominal pressure:	PN 6 up to PN 100 (ANSI 150 lbs up to 600 lbs)
Nominal diameter:	DN 50 (2") up to DN 1600 (64")
Outer-Ø d₄:	The outer- Ø of the carrier rings is a result of (with a smooth-faced sealing face) by subtracting the bolts bore-Ø of the pipe flanges from the hole- Ø. For DIN-flanges you may find the data of the outer- Ø on sheet A8. For tongue and groove arrangements the outer- Ø is d ₄ plus 10mm.
Installation length L:	Standard 65 mm, 40mm; special lengths are possible
Bore- Ø d:	The bore- Ø is carefully calculated by us from the data supplied considering the relevant standards and regulations and is part of the scope of delivery.
Pressure loss:	The remaining pressure loss depends on the nozzle opening ratio $d^2:D^2$ and is approx. 30-80% of dP; you will find this information in the data-sheet.
Pressure taps:	The form and arrangement of pressure taps are described on sheet A6 and A7.
Installation:	Between flanges on horizontal, vertical or diagonal pipelines. Flanges, screws and seals are not part of scope of delivery but may be ordered separately. Concerning the seals you have to consider the regulations regarding the media and conditions of use.
Sealing surface type:	smooth up to PN 100 tongue up to PN 100 DIN 2513 groove up to PN 100 DIN 2512

Dimensional Sketch BLA 200

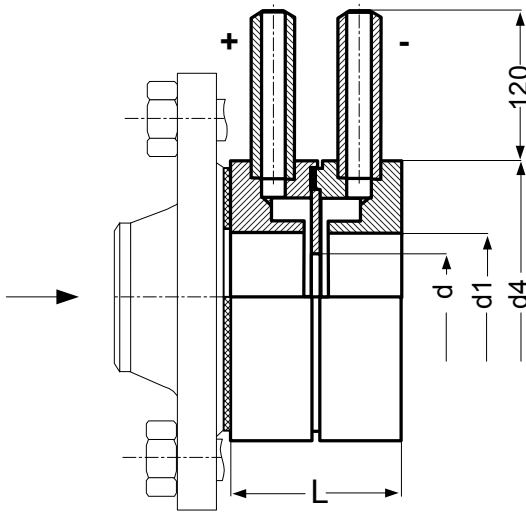

Inner- Ø d1 of carrier ring

From DN 50 up to DN 100: $D + 1 \text{ mm}$
 Above DN 100 up to DN 400: $D + 2 \text{ mm}$
 Above DN 400: $D + 4 \text{ mm}$
 $D = \text{measured-up pipe-}\varnothing$

Identification

Orifice plate number, PN, D, d, material, flow-direction and identification of pressure taps via + and -.

Quality assurance

Production and check go along with the relevant guidelines such as TRD, "AD-Merkblatt" and customer-specifications.

Material certificates according to EN 10204 3.1 A and B.

Materials

The table below shows the customary materials for carrier-rings and orifices. The choice is according to medium, pressure and temperature. The given temperature-scopes are guiding data. Especially for aggressive media you have to consider the individual application.

CARRIER RINGS				ORIFICE PLATES			
Category	Abbreviation	W-No.	Application	Category	Abbreviation	W-No.	Application
Common mild steel acc. to EN 10025/ EN 10028T2	ST 37-2	1.0114	-10 ... +350 °C	Stainless steel acc. to EN 10222-5	X6CrNiTi1810	1.4541	-190 ... +300 °C
	H II	1.0425	-10 ... +390 °C		X6CrNiMoTi17122	1.4571	-60 ... +400 °C
Quality carbon steel	C 22.8	1.0460	-10 ... +490 °C	Heat resistant steel	X10CrAl7	1.4713	up to max. 900 °C
Heat resistant steel	16Mo3	1.5415	up to 530 °C	Corrosion resistant alloys	Hastelloy C Titanium Monel Tantal	2.4602	up to max. 400 °C
	13CrMo45	1.7335	up to 560 °C			3.7035	up to max. 300 °C
Stainless steel acc. to EN 10222-5	X6CrNiTi1810	1.4541	-190 ... +300 °C			2.4360	up to max. 400 °C
	X6CrNiMoTi17122	1.4571	-60 ... +400 °C			Ta	-200 ... +1800 °C
Plastics	PVC PP PE PTFE PVDF		up to max. 70 °C	PRESSURE TAPS			
			up to max. 90 °C	Category	Abbreviation	W-No.	Application
			up to max. 80 °C	Seamless precision steel tube	St 35	1.0308	-10 ... +300 °C
			up to max. 150 °C	Seamless boiler tube acc. to DIN 17175	ST35.8	1.0305	up to max. 500 °C
			up to max. 130 °C		16Mo3	1.5415	up to 530 °C
		13CrMo45	1.7335	up to 560 °C			
			Stainless steel acc. to EN 10222-2	X6CrNiTi1810	1.4541	-190 ... +300 °C	
				X6CrNiMoTi17122	1.4571	-60 ... +400 °C	