

## Meter Runs MBL 500

### Application

Meter runs combine inlet and outlet piping with a flow element which is used for flow measurement of one-phase aggressive and non-aggressive gases, steam or liquids, especially for small pipe diameters up to DN 50 (2"). Due to the integrated in- and outlet pipes flow disturbances can be reduced.

For steam and gas measurements we can include additional taps in the inlet and outlet for pressure and temperature compensation.

### Advantages

In small pipelines the influence of flow disturbances on the measurement is significant. Our inlet and outlet pipes are manufactured to fulfill all requirements which are defined in the calculation standards. This ensures minimum measurement uncertainties. Additionally, the major part of the necessary inlet and outlet pipe length is already included in our design.

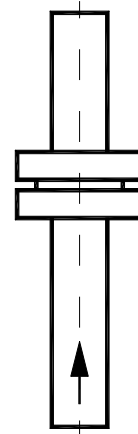

### Standard Installation Lengths L (similar to DIN 19205)

diameter	10 3/8"	15 1/2"	20 3/4"	25 1"	32 1 1/4"	40 1 1/2"	50 2"	65 2 1/2"	80 3"	100 4"	125 5"	150 6"	200 8"
L (mm)	400	550	700	900	1100	1300	1500	1600	1800	2200	2700	3200	4000
L1 (mm)	230	380	500	650	800	1000	1200	1250	1400	1700	2000	2400	3000
L2 (mm)	170	170	200	250	300	300	300	350	400	500	700	800	1000

Different installation lengths are also possible.

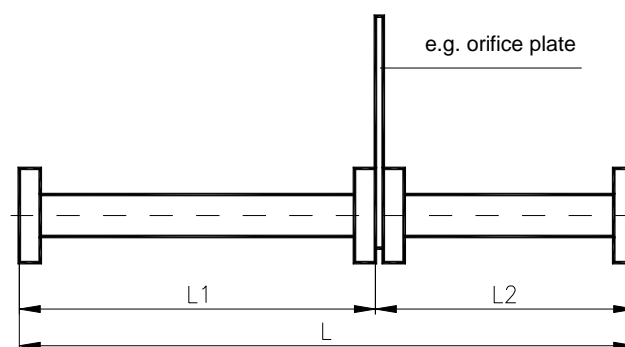

### Measuring Uncertainty

ca. 0,5% - 1,5% of the discharge coefficient C, depending on the use case

### Pressure Loss

The pressure loss depends on the diameter ratio  $\beta$  ( $d/D$ ) and amounts to ca. 30 - 80% of the differential pressure.

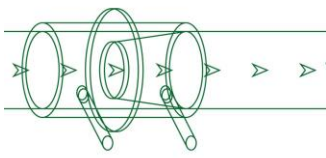

## Installation and Facing

### Flanged ends:

according to EN 1092-1:

- flat (Form B1 and B2)
- groove (Form D)
- female (Form E)

according to ASME B16.5:

- flat (RF and SF)
- groove (small/large)
- female (small/large)
- RTJ female

or according to other flange standards specified by the customer.

### Weld ends:

Weld connection according to the pipe dimensions of the customer.

## Bore Diameter "d"

The calculation of the bore diameter is based on the supplied process data. All relevant standards and regulations will be considered. The calculation is part of the scope of supply.

## Pressure Taps

Pressure taps will be designed according to customer requirements. Typical tap designs are:

- plain ends for fittings
- butt weld ends
- threaded ends
- flanged ends
- compact taps according to IEC 61518

The typical tapping length is ca. 100 mm.

## Installation

For mounting between flanges according to EN 1092-1 / ASME B 16.5 or other standard such as DIN, JIS or BS. The pipe may be positioned horizontally, vertically or sloped.

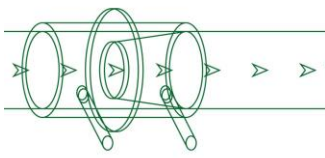

## Calibration

If the requirements dictate the highest measurement quality possible we can perform a calibration of the meter run. This means we determine the flow coefficient "C" empirically on a test bench.

## Marking

Tag no. of flow element

Pressure rating "PN"

Pipe inner diameter "D"

Bore diameter "d"

Material, direction of flow and tagging  
of pressure tapplings with "+" and "-"

## Materials

The following table shows a selection of typical materials utilized for meter runs. The material is chosen based on process medium, pressure and temperature. Other materials are possible as well.

Carrier ring/Flanges	short name	DIN material no.	ASTM / UNS
non-alloy steels	P250GH (C22.8)	1.0460	~ A105
	P265GH (HII)	1.0425	-
	A105	~1.0432	A105
	A516 Gr.60	~1.0436	A516 Gr.60
heat resistant/alloyed steels	16Mo3	1.5415	-
stainless steels	X2CrNiMo17-12-2	1.4404	316L
	X6CrNiMoTi 17 12 2	1.4571	316Ti
high corrosion-resistant alloys	Hastelloy C276	2.4819	N 10276
	Monel 400	2.4360	N 04400
plastics	Polyvinylchloride	PVC	Polyvinylchloride
	Polyethylene	PE	Polyethylene
	PVDF (GRP 25%)	PVDF	PVDF
	Teflon (GRP 25%)	PTFE	PTFE
<b>Orifice plate</b>			
stainless steels	X2CrNiMo17-12-2	1.4404	316L
	X6CrNiMoTi 17 12 2	1.4571	316Ti
high corrosion-resistant alloys	Hastelloy C276	2.4819	N 10276
	Monel 400	2.4360	N 04400
<b>Pipe / Taps</b>			
non-alloy steels	S235G2T	1.0308	-
	P235G1TH	1.0305	-
	A106 Gr.B	~1.0405	A106 Gr.B

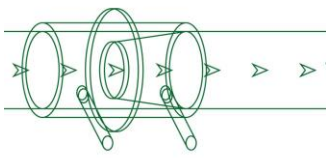

## Quality Control

Manufacture and Test work is done according to the relevant codes and standards such as AD 2000, EN 13480, ASME Codes (without stamp) or customer specifications.

Inspection certificates according to EN 10204 3.1 and 3.2. may be furnished. Special inspections are also possible.

## Accessories

Pipe flanges, bolts/nuts, gaskets for installation, tap valves, condensate pots, manifolds, mounting accessories, calibration may be offered for additional charges.

## Designs

### Design 94D

Our standard design for flow measurement in small pipe diameters. It includes a ring chamber and an orifice plate which can be switched easily. The inlet and outlet pipes form a unit with the ring chambers. An integral design with manifold and DP transmitter is possible.

### Design 94F

Meter run design with a flow element mounted between flanges, e.g. an orifice plate with taps or a nozzle. Taps are located in the flow element or in the in-/outlet pipe.

### Design 94M

Meter run design with an orifice plate BLS 100 mounted between orifice flanges according to ASME B16.36 or DIN 19214.

### Design 96M

Meter run design with a weld-in flow element suited especially for high pressure applications.

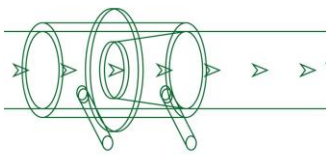

## Meter Run Design 94D

Meter run 94D are flow elements with ring chamber tapping. The orifice plate can be replaced easily. Possible orifice plate types are

- square edge concentric
- quarter circle nozzle
- bidirectional
- plate with conical entrance
- double cone

according to the relevant standards (ISO 5167, ASME MFC-3M etc.). The plate type is chosen based on the specific process conditions. The meter runs are delivered completely mounted. The end connections can be designed as flange ends or weld ends.

## Advantages

The inlet and outlet pipes form a unit with the ring chambers. This results in the lowest flow disturbance possible as any sudden change in the pipe inner diameter is avoided.

The meter run can be adapted to different process conditions easily by switching the removable orifice plate.

Compact design (MBL 500 K):

- External influences such as temperature, vibrations, differences in elevation etc. can be avoided.
- Installation costs are reduced because there is no need for tap pipes to be installed on site.
- We can deliver a meter run complete with manifold and the customer's transmitter, ready for direct usage.

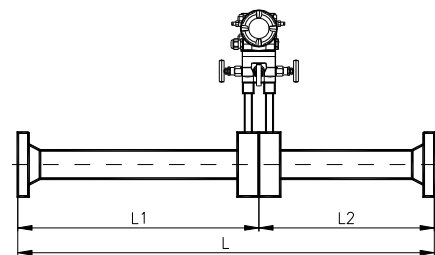
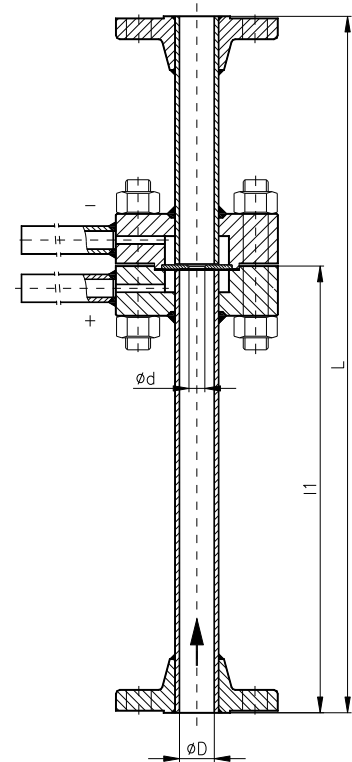

## Nominal Diameter

DN 10 to DN 80 / DN 3/8" to DN 3"

## Pressure Rating

PN 6 to PN 40 / 150# to 300# (for higher pressure ratings please use design 96M)

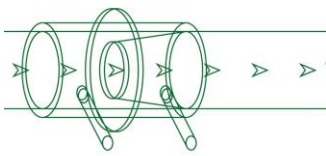

## Meter Run Design 94F

The design 94F combines a meter run with any flow element which can be mounted between flanges, e.g. ring chamber orifice plates BLA 200 or orifice plates with single bore taps BLB 300. Another solution could be an orifice plate without taps BLS 100 where the pressure taps are located in the meter run pipe. Please see the relevant brochures E92 (BLA 200), E93 (BLB 300) or E91N (BLS 100) for more information on the flow elements.

By choosing an appropriate flange facing such as male/ female or groove/ tongue the flow element can be aligned perfectly centric. The meter run will be delivered completely mounted, ready for installation on site. We may offer flanged end connection or weld end connection.

## Advantages

Installation disturbances, e.g. sagging of the weld seam root, can be avoided by subsequent mechanical processing. Additionally, we can ensure the correct mounting of the flow element before shipping it to the installation site.

## Nominal Diameter

DN 50 to DN 250 / DN 2" to DN 10",  
other sizes are possible.

## Pressure Rating

PN 6 to PN 100 / 150# to 600# (ASME)

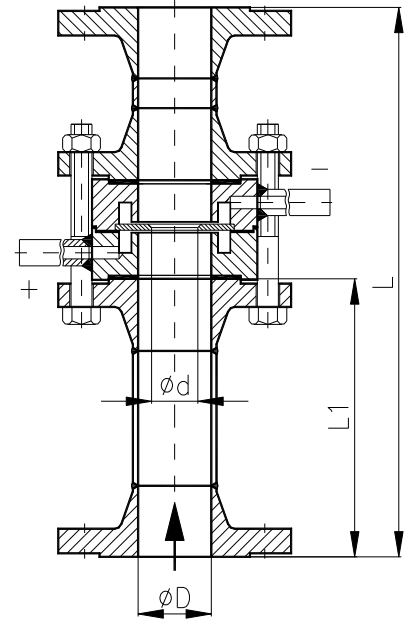

Meter run with a ring chamber orifice plate

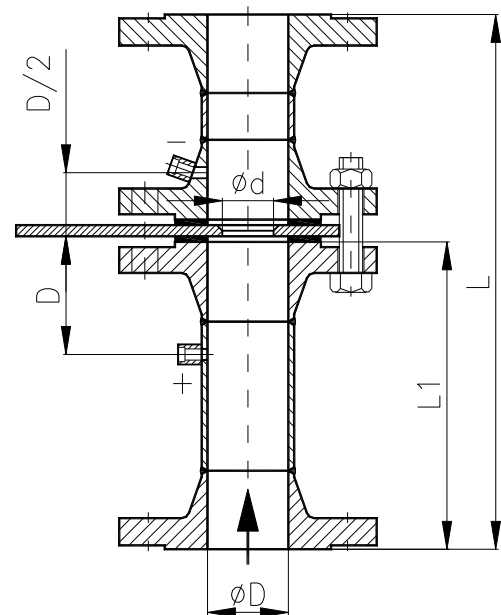

Meter run with an orifice plate and "D and D/2 pressure tappings"

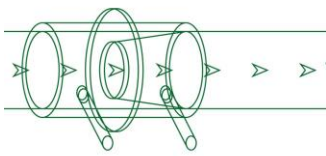

## Meter Run Design 94M

The design 94M combines a meter run with orifice flanges (e.g. according to DIN 19214 or ASME B16.36) and an orifice plate BLS 100. Please check the brochure E91N/F for more information on orifice plates and orifice flanges. The meter run will be delivered completely mounted, ready for installation on site. We may offer flanged end connection or weld end connection.

## Advantages

Installation disturbances, e.g. sagging of the weld seam root, can be avoided by subsequent mechanical processing. Additionally, we can ensure the correct mounting of the flow element before shipping it to the installation site.

## Nominal Diameter

DN 10 to DN 200 / DN 1/2" to DN 8",  
other sizes are possible.

## Pressure Rating

PN 6 to PN 400 / 150# to 2500# (ASME)

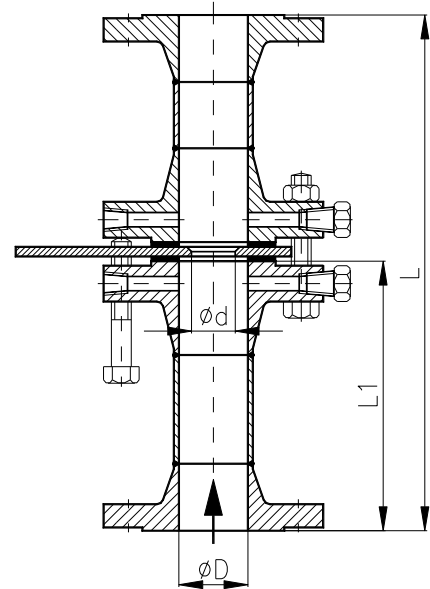

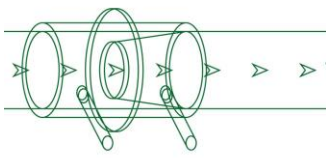

## Meter Run Design 96M

Meter run design 96M are flow elements with welded ring chamber tappings. This design is well suited for high pressure and high temperature applications. The orifice plate can be manufactured as

- square edge concentric
- bidirectional
- quarter circle nozzle
- plate with conical entrance
- double cone

according to the relevant standards (ISO 5167, ASME MFC-3M etc.). The plate type is chosen based on the specific process conditions. Generally, we offer weld end connections.

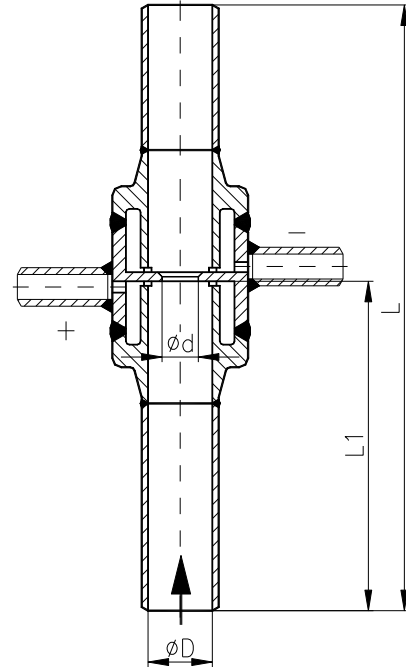

## Advantages

The welded construction avoids any leakage of the flow medium. All welding seams can be analyzed via radiographic examinations or other NDE procedures. Installation disturbances, e.g. sagging of the weld seam root, are avoided by subsequent mechanical processing.

## Nominal Diameter

DN 10 to DN 50 / DN 1/2" to DN 2",  
other sizes are possible.

## Pressure Rating

PN 63 to PN 400 / 600# to 2500# (ASME),  
lower pressure ratings are possible on request.

## Installation

This meter run design can be directly welded to the pipe on site. If necessary, we can make respective adjustments to the end connection dimensions.